

# Uplifter SPT499

Mini crane | Uplifter



Load capacity	5.000 kg
Working height max.	ca. 17,5 m (ca. 22,0 m incl. Jib)
Assembly tip	✓
Radio remote control	✓
Crane under ground	17.5 m/4-fold, 35.0 m/2-fold, 70.0 m/1-fold Shear
Drive	Hybrid (electric and diesel engine)
Climbing ability	max. 20° or 36 %
Length*	5,48 m
Wide*	1,40 m
Height*	2,00 m
Dead weight*	6.200 kg
Accessories	Hydraulic jib, manual jib, tool box, white tracks, load distribution plates for the outriggers.

\* depending on equipment

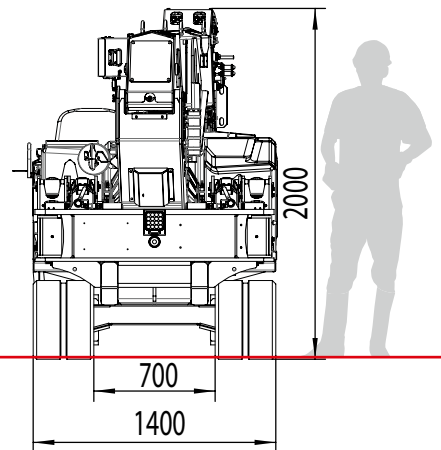
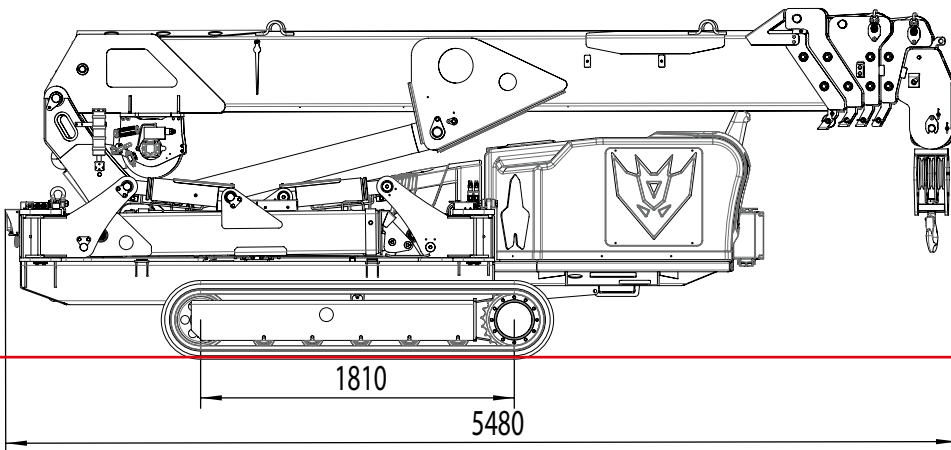

Load diagram (t)

Load diagram (t)

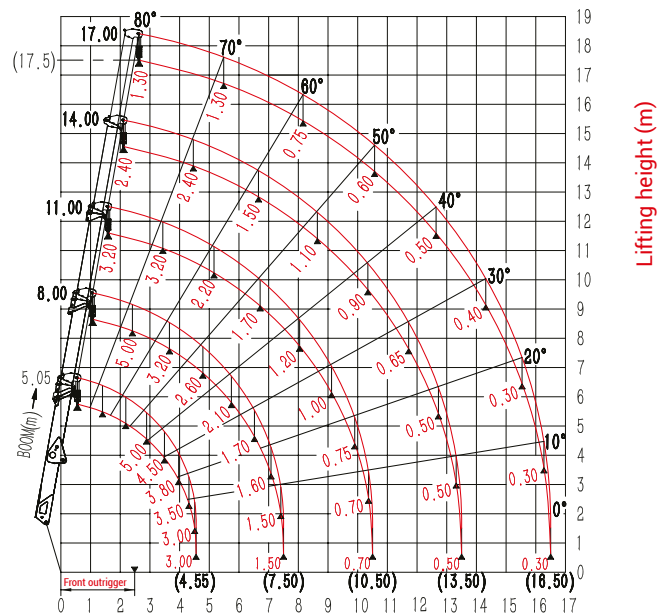
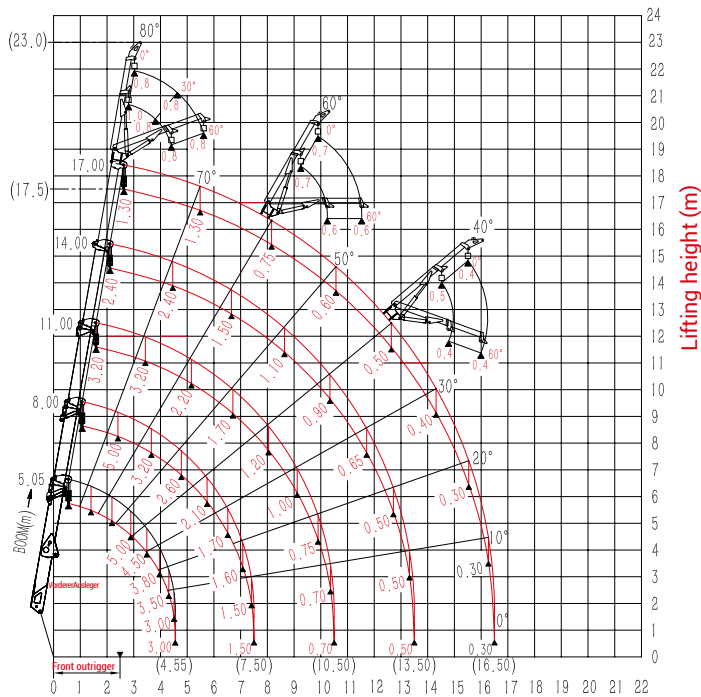

Extend outrigger to maximum Working range (m)

Extend outrigger to maximum Working range (m)